

# NOVEDADES

ews  
ouveautés

---

<b>Lavamanos portátil gran caudal</b> Mobile and autonomous hand wash basin high flow Lave-mains sur pied autonome et portable d'grand débit .....	<b>137</b>
<b>Lavamanos de columna electrónico de agua fría y caliente</b> Electronically-operated hot and cold-water column hand wash basin Lave-mains de colonne électronique à eau froide et chaude .....	<b>144</b>
<b>Lavamanos mural de rodilla modelo RC de agua fría y caliente</b> Knee-operated hot and cold-water wall mounted hand wash basin RC model Lave-mains mural à actionnement par genou eau froide et chaude modèle RC .....	<b>145</b>
<b>Fuente de columna</b> Column fountain Fontaine colonne .....	<b>154</b>
<b>Fuente de columna de pedal</b> Pedal-operated column fountain Fontaine colonne avec pédale .....	<b>154</b>
<b>Fuente mural redonda</b> Wall-mounted round fountain Fontaine mural ronde .....	<b>155</b>
<b>Fuente mural de esquina</b> Wall-mounted corner fountain Fontaine mural d'angle .....	<b>155</b>



LAVAMANOS  
Hand wash basins  
Lave-mains





### Main characteristics:

Fully constructed of stainless steel  
 Autonomous system which makes any water inlet, drainpipe or electric unnecessary.  
 This unit works by means of a hydraulic push-button which pumps clean water from one of the interior 10 litre tanks whereas the dirty water is poured into the other 10 litre tank. It possesses an anti odour system.  
 With rear handle and back wheels to make easy to move around.  
 Top sink of large capacity with front rounded corners and high resistance fabrication. It is provided with anti-drip edges.  
 The frame is closed on three sides, with interior shelf and front detachable door.  
 Discrete wastepaper bin built in the unit. Comfortable access to the wastepaper bin through a swing lid.  
 Anti-splash panel installed.  
 Battery working automatic soap dispenser 1lt.  
 Tissues dispenser. The case allows the placing of standard boxes with tissues, globes, shoe covers, face masks, etc.

### Caractéristiques principales:

Totalement construit en acier inoxydable  
 Système autonome, il ne requiert pas de prise d'eau d'entrée ni déversoir. Il ne requiert pas non plus d'installation électrique. Il fonctionne avec un poussoir hydraulique qui pompe l'eau d'un réservoir de 10 litres situé à l'intérieur du lave-mains. L'autre réservoir est pour l'eau sale.  
 Il est pourvu d'une poignée postérieure et de roulettes pour mieux le déplacer.  
 Le bac a les arêtes frontales rondies, ce qui favorise la résistance. Le bac a aussi un rebord pour éviter les chutes d'eau.  
 L'armoire est fermée par les trois cotés, avec étagère inférieure et porte frontale.  
 Il y a une corbeille à papier à l'intérieur du lave-mains. L'accès à la corbeille est confortable et discret, avec une trappe basculante.  
 Le dossiereret postérieur est inclus.  
 Distributeur de savon automatique à piles 1 litre.  
 Il est muni d'un distributeur d'essuie-mains qui permet d'introduire des boîtes de taille standard et qui peut être utilisé aussi comme distributeur de gants et de masques.



Esquinas redondeadas  
 Rounded corners  
 Coins arrondis

### Características principales de lavamanos autónomos:

Totalmente construido en acero inoxidable.  
 Sistema autónomo que no precisa instalación de tomas de agua, desagüe e instalación eléctrica.  
 Este sistema funciona mediante un pulsador hidráulico que bombea el agua limpia desde uno de los depósitos de 10 lts situados en su interior, el otro es para el agua sucia. Dispone de sistema anti-olores.  
 Con asa de arrastre posterior y ruedas para su fácil transporte.  
 Cubeta con aristas frontales redondeadas, de gran dimensión y alta resistencia, provista de reborde anti-derrames.  
 Armario cerrado por tres lados, con estante interior y puerta frontal.  
 Papelera integrada dentro del mueble. Cómodo y discreto acceso a papelera mediante trampilla basculante.  
 Peto trasero anti salpicaduras instalado.  
 Dosificador de jabón automático de 1 litro (funcionamiento a pilas)  
 Dispensador de tisús. Permite la introducción de cajas de tamaño estándar con tisús, guantes, calzas, mascarillas, etc.



Ideal para lugares donde:  
 No hay tomas de agua.  
 No hay desagüe.  
 No hay instalación eléctrica.

Perfecto para eventos al aire libre, clínicas, ferias, exposiciones, mercados, etc.

Ideal for places where:  
 There are no water installation  
 There are no drain installation  
 There are no electrical installation

Perfect for outdoor events, clinics, fairs, exhibitions, markets, etc.

Il est conçu spécialement pour des places où:  
 Il n'y a pas de prises d'eau.  
 Il n'y a pas de déversoirs.  
 Il n'y a pas de courante électrique.

Parfait pour des événements en plein air, cliniques, foires, expositions, marchés ambulants...



## Lavamanos portátil autónomo

Mobile and autonomous hand wash basin  
Lave-mains sur pied autonome et portable

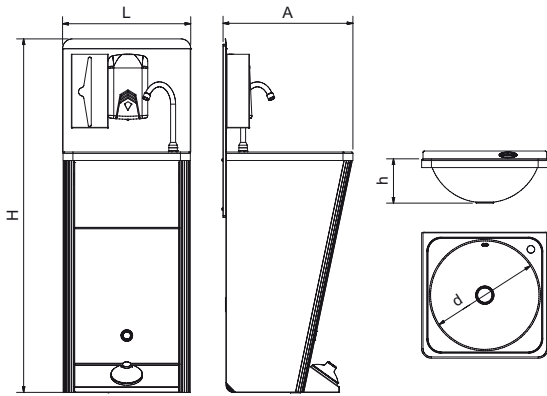

### Dimensiones

Dimensions  
Dimensions

L	A	H	d	h	Kg		€
450	450	1.250	390	150	18,00	9,5	061430 750,00

- Includido / Included / Inclus
- Opcional / Optional / Optionnel



## Lavamanos portátil gran caudal

Mobile and autonomous hand wash basin high flow  
Lave-mains sur pied autonome et portable d'grand débit

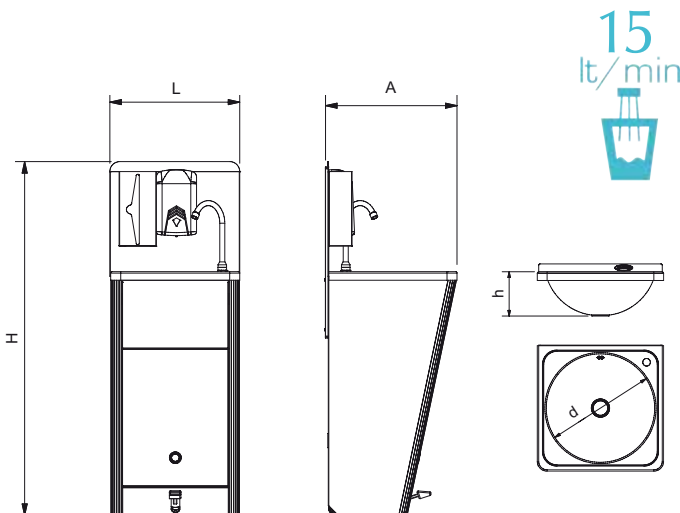

### Dimensiones

Dimensions  
Dimensions

L	A	H	d	h	Kg		€
450	450	1.250	390	150	18,00	15	061428 980,00



## Accesorios para lavamanos portátiles autónomos

Mobile and autonomous hand wash basins accessories  
Accessoires pour lave-mains sur pied autonome et portable

### Opción de agua caliente para lavamanos autónomo

Optional hot water for mobile washbasin  
Eau chaude optionnelle pour lave-mains portables

	Potencia Power Puissance	Tensión Voltage Tension	Frecuencia Frequency Fréquence	Barcode	€
	34°C 100 W	220 V	50/60 Hz	061450	42,00
	34°C 100 W	12 V		061452	136,00
	34°C 200 W	220 V	50/60 Hz	061454	79,00



- Kit para temperatura ambiente inferior a 15 °C.  
Accessory for room temperature below 15 °C.  
Kit pour température ambiante moins de 15 °C.



## Lavamanos integral registrable

Integral hand wash basin with removable door  
Lave-mains intégral avec porte amovible



**Papelera integrada**  
Waste bin integrated  
Corbeille à papier intégrée

### Dotación de serie:

Lavamanos completo, agua fría y caliente.  
Papelera integrada en el mueble.  
Peto trasero.  
Dispensador de toallas en acero inoxidable.  
Dispensador de jabón en acero inoxidable capacidad 0,8 lt.

### Equipment and fittings included:

Fully equipped hand wash basin, hot and cold water.  
Wastepaper bin incorporated into the unit.  
Backsplash.  
Towel dispenser in stainless steel.  
Soap dispenser in stainless steel - capacity 0.8 litres.

### Équipement et accessoires inclus:

Lave-mains complet, à l'eau froide et chaude.  
Corbeille à papier incorporé.  
Cuirasse postérieure.  
Dispensateur d'essuie-mains en acier inoxydable.  
Doseur de savon en acier inoxydable - capacité 0.8 litres.



**Esquinas redondeadas**  
Rounded corners  
Coins arrondis



**Provistos de mezclador antirretorno**  
Supplied with no-return mixing valve  
Munies de valve antiretour mélangeuse



**Funcionamiento a pilas**  
Batteries functioning  
Fonctionnement à piles

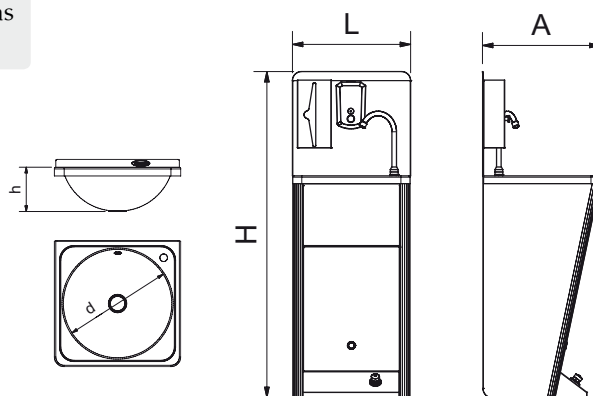

Funcionamiento Functioning Fonctionnement	Dimensiones Dimensions Dimensions							€
	L	A	H	d	h	Kg	Barcode	
Pulsador de pie Foot push button Poussoir à pied	450	450	1.250	390	150	14,20	061414	465,00
Electrónico Electronical Électronique	450	450	1.250	390	150	15,20	061418	649,00

**Lavamanos integral mural**  
Wall-mounted integral hand wash basin  
Lave-mains mural intégral

**Dotación de serie:**

Lavamanos completo, agua fría y caliente.  
Papelera ergonómica.  
Peto trasero.  
Dispensador de toallas en acero inoxidable.  
Dispensador de jabón en acero inoxidable capacidad 0,8 lt.

**Equipment and fittings included:**

Full hand wash basin, hot and cold water.  
Designer wastepaper bin.  
Backsplash.  
Towel dispenser in stainless steel.  
Soap dispenser in stainless steel - capacity 0.8 litres.

**Équipement et accessoires inclus:**

Lave-mains complet, à l'eau froide et chaude.  
Corbeille à papier ergonomique.  
Cuirasse postérieure.  
Dispensateur d'essuie-mains en acier inoxydable.  
Doseur de savon en acier inoxydable - capacité 0.8 litres.



**Esquinas redondeadas**  
Rounded corners  
Coins arrondis



**Provistos de mezclador antirretorno**  
Supplied with no-return mixing valve  
Munies de valve antiretour mélangeuse



**Funcionamiento a pilas**  
Batteries functioning  
Fonctionnement a piles

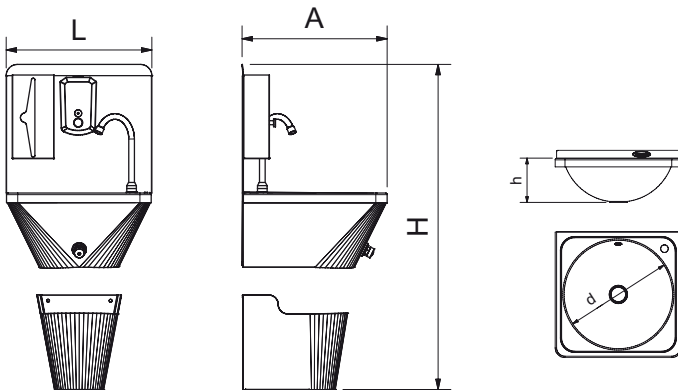

Funcionamiento Functioning Fonctionnement	Dimensiones Dimensions Dimensions							€
	L	A	H	d	h	Kg	Barcode	
<b>Pulsador rodilla</b> Knee push button Poussoir genou	450	450	1.050	390	150	10,49	061406	<b>410,00</b>
<b>Electrónico</b> Electronical Électronique	450	450	1.050	390	150	12,66	061410	<b>620,00</b>



## Lavamanos serie XS

Hand wash basin XS model  
Lave-main modèle XS



### La serie de lavamanos XS

Por sus reducidas dimensiones está diseñada para adaptarse a las instalaciones con poco espacio. Su funcionalidad es perfecta, a pesar de su pequeño tamaño, pues incorporamos una nueva cubeta de alto espesor y gran capacidad con reborde antiderrames que asegura su utilidad.

Construidos en acero inoxidable acabado esmerilado Scotch-brite, disponen de una válvula mezcladora antiretorno con la que podrá regular la temperatura de servicio. El modelo registrable cuenta con una papelera incorporada en el mueble.

### The range of hand wash basins XS

It is designed to fit up areas with little room because of its reduced dimensions. Although its small size, it is functionally perfect, since it has a new tank of large capacity, and anti-overflow rim, which ensure its usefulness.

It is made of stainless steel emery polished with scotch-brite finishing. They have a non return mixing valve that will allow you to regulate the temperature. The model with removable door has a wastepaper bin in the piece of furniture.



### Les modèles de lave-mains XS

Sont conçus pour s'adapter aux installations où on dispose de peu d'espace. Sa fonctionnalité est parfaite, puisqu'il a un nouveau bac à grande capacité, et rebord pour éviter des trop-pleins.

Construit en acier inoxydable poli à l'émeri avec finition Scotch-brite. Il a une valve mélangeuse anti-retour qui permet régler la température. Le modèle à porte amovible a une corbeille à papier dans le meuble.



460220 38,00 309

Dosificadores de jabón  
Soap dispenser  
Doseur de savon



060608 26,00 150

Peto postizo para acoplar  
Detachable stand to be fitted to hand wash basin  
Support amovible pour accoupler au lave-mains



080602 63,00 287

Papelera  
Wastepaper bin  
Corbeille à papier

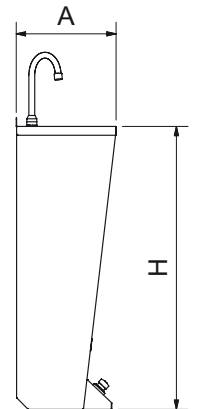
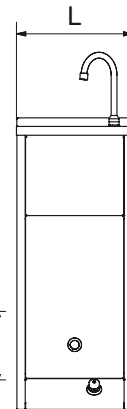
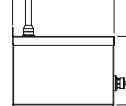
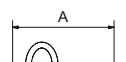
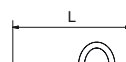
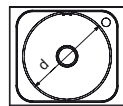

- Incluido / Included / Inclus
- Opcional / Optional / Optionnel



Provistos de mezclador antiretorno  
Supplied with no-return mixing valve  
Munies de valve antiretour mélangeuse

Funcionamiento Functioning Fonctionnement	Dimensiones Dimensions Dimensions							€
	L	A	H	d	h	Kg		
Registrable Removable Amovible	350	300	850	260	115	9,00	061426	307,00
Pulsador rodilla Knee push button Poussoir genou	350	300	215	260	115	3,91	061422	190,00

## Lavamanos mural de esquina - serie XS

Wall-mounted corner hand wash basin XS model  
Lave-main mural d'angle modèle XS



061424

**Ejemplo de lavamanos de esquina con peto postizo opcional 060612**  
Example of corner hand-washbasin with optional backsplash code 060612  
Exemple de lave-main d'angle avec dossier optionnel code 060612



061424 + 060612

Spécial pour des établissements où il n'y a pas beaucoup de place. Malgré sa petite taille, sa fonctionnalité est parfaite : il a un bac de grand épaisseur et haute capacité.  
Commande fémorale avec bouton poussoir.  
Totalement construit en acier inoxydable. Finition brossé mat.  
Il est pourvu d'une valve anti-retour mélangeuse, qui sert à sélectionner la quantité d'eau froide et chaude qui rentre dans le circuit.  
Le col de cygne est inclus, ainsi que toutes les pièces nécessaires pour l'installation.

Por sus reducidas dimensiones está diseñado para adaptarse a las instalaciones con poco espacio. Su funcionalidad es perfecta, a pesar de su pequeño tamaño, pues incorporamos una nueva cubeta de alto espesor y gran capacidad que asegura su utilidad.  
Accionamiento de rodilla mediante un pulsador.  
Totalmente construido en acero inoxidable. Acabado mate satinado. Está provisto de una válvula anti retorno mezcladora que le permite seleccionar el caudal de agua fría y caliente que entran en el circuito. Caño incluido, así como todas las piezas necesarias para su instalación.

It is designed to fit up areas with little room because of its reduced dimensions. Although its small size, it is functionally perfect, since it has a new tank of large capacity, which ensure its usefulness.  
Knee-operated with push button.  
Made completely in stainless steel. Satin finish. It is provided with a non-return mixing valve that allows you to select the water temperature. The swan neck tap and all the accessories needed for the assembly are included.



**Provistos de mezclador antirretorno**  
Supplied with no-return mixing valve  
Munies de valve antiretour mélangeuse

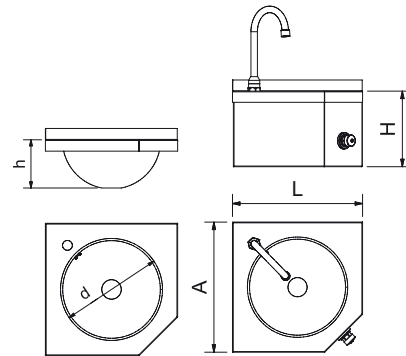

### Dimensiones

Dimensions  
Dimensions

L	A	H	d	h	Kg	Barcode	€
350	350	205	260	115	3,00	061424	307,00

## Lavamanos mural serie XS - dos aguas

Double tap hand wash basin XS model  
Lave-main à deux eaux modèle XS

Por sus reducidas dimensiones está diseñado para adaptarse a las instalaciones con poco espacio. Su funcionalidad es perfecta, a pesar de su pequeño tamaño, pues incorporamos una nueva cubeta de alto espesor y gran capacidad con reborde antiderrames que asegura su utilidad.  
Construido en acero inoxidable  
Se suministra con grifería, válvula de desagüe y rebosadero.

It is designed to fit up areas with little room because of its reduced dimensions. Although its small size, it is functionally perfect, since it has a new tank of large capacity, and anti-overflow rim, which ensure its usefulness.  
Fully made of stainless steel.  
Supplied with taps, waste and overflow.

Sont conçus pour s'adapter aux installations où on dispose de peu d'espace. Sa fonctionnalité est parfaite, puisqu'il a un nouveau bac à grande capacité, et rebord pour éviter des trop-pleins.  
Fabriqué en acier inoxydable.  
Fourni avec robinets et valve d'écoulement avec déversoir.

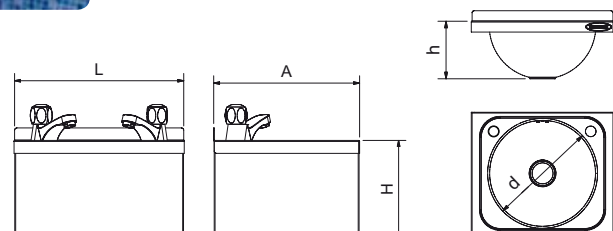

### Dimensiones

Dimensions  
Dimensions

L	A	H	d	h	Kg	Barcode	€
350	300	200	260	115	2,32	061432	250,00

## Lavamanos registrable con pedal de agua fría y caliente

Pedal-operated hot and cold-water hand wash basins

Lave-mains à actionnement par pédale d'eau froide et chaude



Provistos de mezclador antirretorno  
Supplied with no-return mixing valve  
Munies de valve antiretour mélangeuse

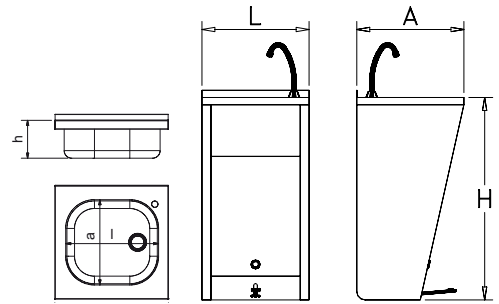

Dimensiones Dimensions Dimensions			Dimensiones de la cubeta Tank dimensions Dimensions du bac							
L	A	H	l	a	h	Kg		€		
450	450	850	370	340	150	11,96	061004	350,00		

## Lavamanos registrable con doble pedal de agua fría y caliente

Twin pedal-operated hot and cold-water hand wash basins

Lave-mains à actionnement par double pédale d'eau froide et chaude

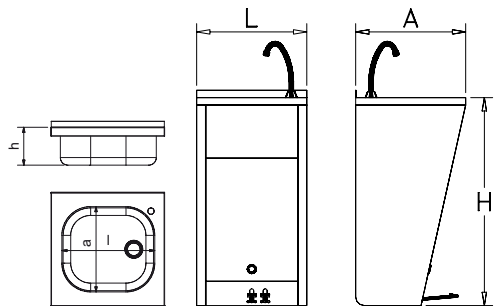

Dimensiones Dimensions Dimensions			Dimensiones de la cubeta Tank dimensions Dimensions du bac							
L	A	H	l	a	h	Kg		€		
450	450	850	370	340	150	12,66	061008	370,00		

## Lavamanos registrable de rodilla agua fría y caliente

Knee-operated hot and cold-water hand wash basins

Lave-mains à actionnement par genou eau froide et chaude



Provistos de mezclador antirretorno  
Supplied with no-return mixing valve  
Munies de valve antiretour mélangeuse

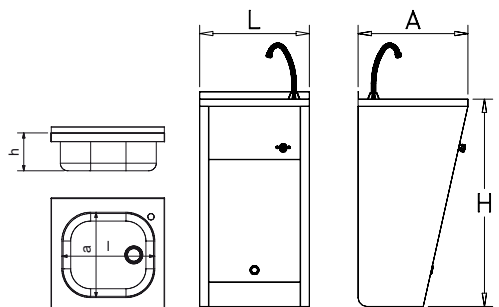

Dimensiones Dimensions Dimensions			Dimensiones de la cubeta Tank dimensions Dimensions du bac							
L	A	H	l	a	h	Kg		€		
450	450	850	370	340	150	11,96	061002	325,00		



## Lavamanos registrable con pedestal un pulsador agua fría y caliente

One push – button hand wash basin, cold and hot water  
Lave-mains avec piédestal, un poussoir, d'eau froide et chaude

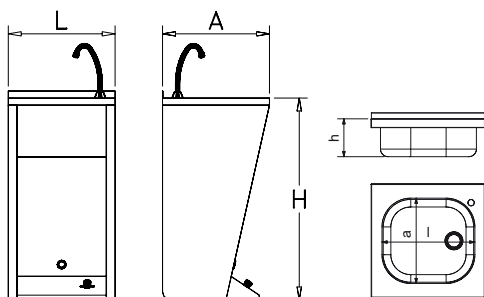

Provistos de mezclador antirretorno

Supplied with no-return mixing valve  
Munies de valve antiretour mélangeuse



Dimensiones Dimensions Dimensions			Dimensiones de la cubeta Tank dimensions Dimensiones du bac				Kg	Barcode	€
L	A	H	I	a	h				
450	450	850	370	340	150	12,00	061012	299,00	

## Lavamanos registrable con pedestal doble pulsador agua fría y caliente

Double push buttons hand wash basin, cold and hot water  
Lave-mains avec piédestal, deux poussoirs d'eau froide et chaude

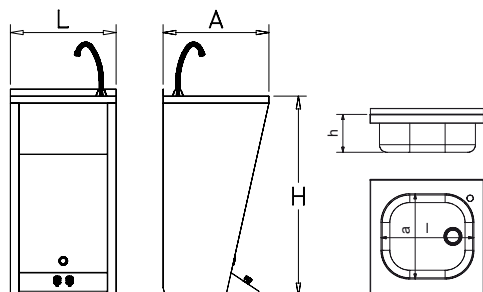

Dimensiones Dimensions Dimensions			Dimensiones de la cubeta Tank dimensions Dimensiones du bac				Kg	Barcode	€
L	A	H	I	a	h				
450	450	850	370	340	150	12,00	061014	340,00	

## Lavamanos registrable electrónico de agua fría y caliente

Electronically-operated hot and cold-water hand wash basins  
Lave-mains à actionnement électronique à eau froide et chaude



Provistos de mezclador antirretorno

Supplied with no-return mixing valve  
Munies de valve antiretour mélangeuse



Funcionamiento a pilas

Batteries functioning  
Fonctionnement a piles

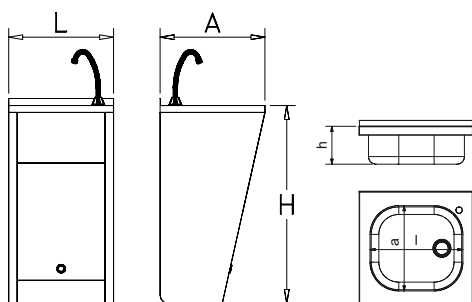

### Máxima fiabilidad:

No necesita instalación eléctrica, pues su funcionamiento es a pilas.  
Evita cualquier accidente derivado de las instalaciones eléctricas y el agua.  
Duración aproximada de las pilas: 6 meses.

### Maximum fiability:

It is not necessary an electrical installation, since its functioning is by batteries.  
It avoids any accident derived from electrical installations and water.  
Approximate batteries life: 6 months.

### Maximum fiabilité:

Il ne précise pas d'installation électrique puisque son fonctionnement c'est à piles.  
Évite quelque accident provoqué par les installations d'électricité et l'eau.  
Durée approchée des piles: 6 mois.

Dimensiones Dimensions Dimensions			Dimensiones de la cubeta Tank dimensions Dimensiones du bac				Kg	Barcode	€
L	A	H	I	a	h				
450	450	850	370	340	150	12,54	061010	530,00	

## Lavamanos de columna electrónico de agua fría y caliente

Electronically-operated hot and cold-water column hand wash basin

Lave-mains de colonne électronique à eau froide et chaude



Provistos de mezclador antirretorno  
Supplied with no-return mixing valve  
Munies de valve antiretour mélangeuse



Funcionamiento a pilas  
Batteries functioning  
Fonctionnement a piles

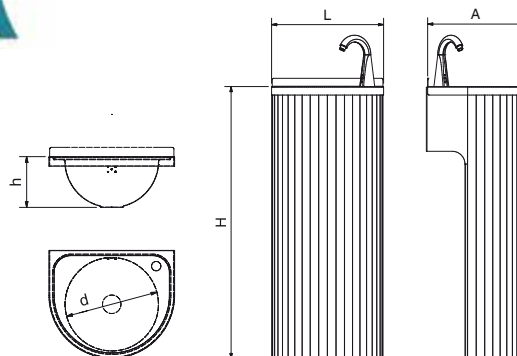

Dimensiones Dimensions Dimensions			Dimensiones de la cubeta Tank dimensions Dimensions du bac					
L	A	H	d	h	Kg		€	
350	300	850	260	115	7,00	061462	549,00	

## Lavamanos mural con pedal de agua fría y caliente

Pedal-operated hot and cold-water wall-mounted hand wash basins

Lave-mains mural avec pédale d'eau froide et chaude



Provistos de mezclador antirretorno  
Supplied with no-return mixing valve  
Munies de valve antiretour mélangeuse

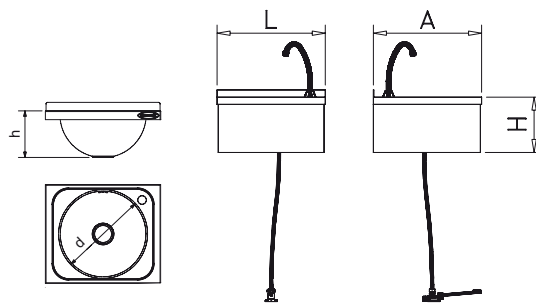

Dimensiones Dimensions Dimensions			Dimensiones de la cubeta Tank dimensions Dimensions du bac					
L	A	H	d	h	Kg		€	
450	450	215	390	150	5,46	061204	244,00	

## Lavamanos mural con doble pedal de agua fría y caliente

Twin pedal-operated hot and cold-water wall-mounted hand wash basins

Lave-mains mural avec double pédale à eau froide et chaude

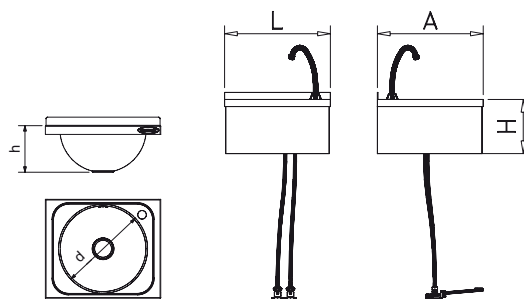

Dimensiones Dimensions Dimensions			Dimensiones de la cubeta Tank dimensions Dimensions du bac					
L	A	H	d	h	Kg		€	
450	450	215	390	150	6,6	061208	288,00	

## Lavamanos mural de rodilla agua fría y caliente

Knee-operated hot and cold-water wall-mounted hand wash basins  
Lave-mains mural à actionnement par genou eau froide et chaude

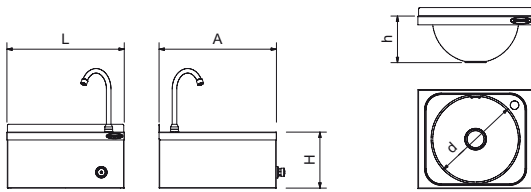

Provistos de mezclador antirretorno  
Supplied with no-return mixing valve  
Munies de valve antiretour mélangeuse

Dimensiones Dimensions Dimensions			Dimensiones de la cubeta Tank dimensions Dimensiones du bac					
L	A	H	d	h	Kg		€	
450	450	215	390	150	5,59	061202	217,00	

## Lavamanos mural de rodilla modelo RC de agua fría y caliente

Knee-operated hot and cold-water wall mounted hand wash basin RC model  
Lave-mains mural à actionnement par genou eau froide et chaude modèle RC



Provistos de mezclador antirretorno  
Supplied with no-return mixing valve  
Munies de valve antiretour mélangeuse

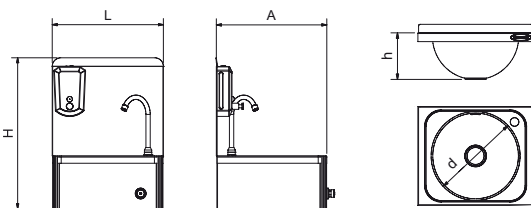

**N**ovedad  
NEW  
NOUVEAU

Esquinas redondeadas  
Rounded corners  
Coins arrondis

Dimensiones Dimensions Dimensions			Dimensiones de la cubeta Tank dimensions Dimensiones du bac					
L	A	H	d	h	Kg		€	
453	450	615	390	150	7,00	061212	360,00	

## Lavamanos mural de palanca agua fría y caliente

Handle-operated hot and cold water wall-mounted hand wash basin  
Lave-mains mural à levier eau foide et chaude

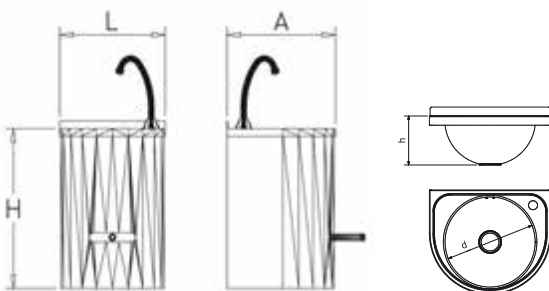

Provistos de mezclador antirretorno  
Supplied with no-return mixing valve  
Munies de valve antiretour mélangeuse

Dimensiones Dimensions Dimensions			Dimensiones de la cubeta Tank dimensions Dimensiones du bac					
L	A	H	d	h	Kg		€	
350	300	500	260	115	8,00	061402	425,00	

## Lavamanos mural electrónico de agua fría y caliente

Electronically-operated hot and cold-water wall-mounted hand wash basins  
Lave-mains mural électronique d'eau à eau froide et chaude



**Funcionamiento a pilas**  
Batteries functioning  
Fonctionnement à piles



**Provistos de mezclador antirretorno**  
Supplied with no-return mixing valve  
Munies de valve antiretour mélangeuse

### Máxima fiabilidad:

No necesita instalación eléctrica, pues su funcionamiento es a pilas. Evita cualquier accidente derivado de las instalaciones eléctricas y el agua.

Duración aproximada de las pilas: 6 meses.

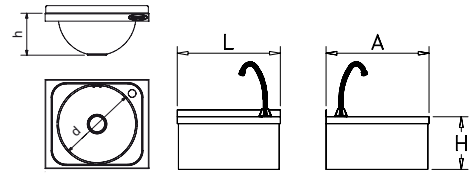

### Maximum fiability:

It is not necessary an electrical installation, since its functioning is by batteries. It avoids any accident derived from electrical installations and water.

### Maximum fiabilité:

Il ne précise pas d'installation électrique puisque son fonctionnement c'est à piles. Évite quelque accident provoqué par les installations d'électricité et l'eau. Durée approchée des piles: 6 mois.

Dimensiones Dimensions Dimensions			Dimensiones de la cubeta Tank dimensions Dimensions du bac				
L	A	H	l	h	Kg	Barcode	€
450	450	215	390	150	6,14	061210	395,00

## Lavamanos mural electrónico de agua fría y caliente

Electronically-operated hot and cold-water wall-mounted hand wash basins  
Lave-mains mural électronique d'eau à eau froide et chaude



**Provistos de mezclador antirretorno**  
Supplied with no-return mixing valve  
Munies de valve antiretour mélangeuse

### Máxima fiabilidad:

No necesita instalación eléctrica, pues su funcionamiento es a pilas. Evita cualquier accidente derivado de las instalaciones eléctricas y el agua.

### Maximum fiability:

It is not necessary an electrical installation, since its functioning is by batteries. It avoids any accident derived from electrical installations and water.

Approximate batteries life: 6 months.

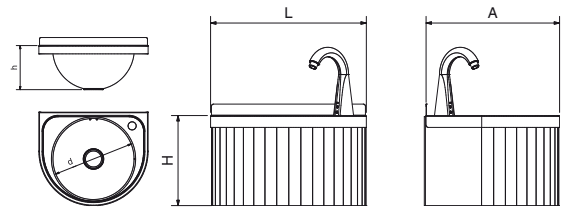

**Funcionamiento a pilas**  
Batteries functioning  
Fonctionnement à piles

### Maximum fiabilité:

Il ne précise pas d'installation électrique puisque son fonctionnement c'est à piles. Évite quelque accident provoqué par les installations d'électricité et l'eau. Durée approchée des piles: 6 mois.

Dimensiones Dimensions Dimensions			Dimensiones de la cubeta Tank dimensions Dimensions du bac				
L	A	H	d	h	Kg	Barcode	€
350	300	200	260	115	6	061404	509,00

## Lavamanos mural electrónico con selector de temperatura

Electronically-operated wall mounted had wash basin with temperature selector  
Lave-mains mural électronique avec sélecteur de température



**Funcionamiento a pilas**  
Batteries functioning  
Fonctionnement à piles

### Máxima fiabilidad:

No necesita instalación eléctrica, pues su funcionamiento es a pilas. Evita cualquier accidente derivado de las instalaciones eléctricas y el agua.

Duración aproximada de las pilas: 6 meses.

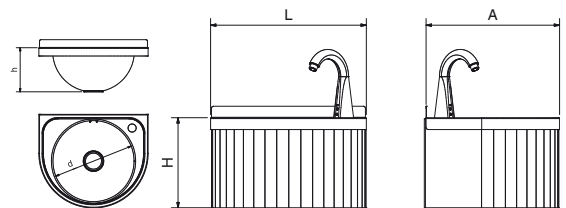

### Maximum fiability:

It is not necessary an electrical installation, since its functioning is by batteries. It avoids any accident derived from electrical installations and water.

### Maximum fiabilité:

Il ne précise pas d'installation électrique puisque son fonctionnement c'est à piles. Évite quelque accident provoqué par les installations d'électricité et l'eau. Durée approchée des piles: 6 mois.

Dimensiones Dimensions Dimensions			Dimensiones de la cubeta Tank dimensions Dimensions du bac				
L	A	H	d	h	Kg	Barcode	€
350	300	200	260	115	6	061448	559,00

**Lavamanos mural colectivo de rodilla agua fría y caliente**  
 Knee-operated hot and cold water wall-mounted collective washbasin  
 Lave-main mural collectif à actionnement par genou eau froide et chaude



460252 133,00 304

**Espejo Inox**  
 Stainless steel mirror  
 Miroir inox



065004 720,00 300

**Urinario inox**  
 Inox urinal  
 Urinoir inox



**Provisos de mezclador antirretorno**  
 Supplied with no-return mixing valve  
 Munies de valve antiretour mélangeuse

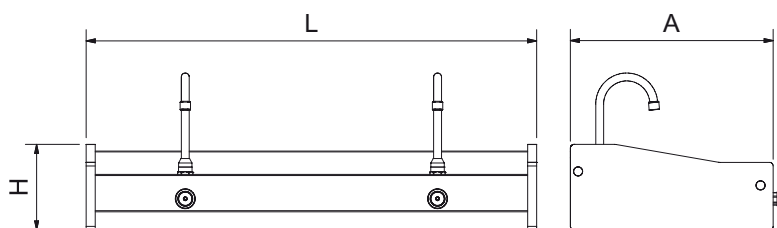

Dimensiones Dimensions Dimensions							
L	A	H		Kg		€	
1.000	450	190	2	12	061436	<b>500,00</b>	
1.500	450	190	3	17	061438	<b>670,00</b>	
2.000	450	190	4	22	061440	<b>795,00</b>	

**Lavamanos mural colectivo**  
 Wall-mounted collective washbasin  
 Lave-main mural collectif



**Sin accesorios ni taladros.**  
 Without accessories or drills  
 Sans accessoires ni poinçonnages

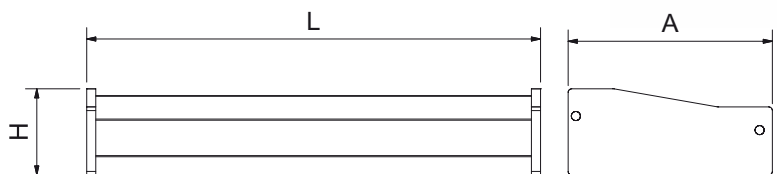

Dimensiones Dimensions Dimensions						
L	A	H	Kg		€	
1.000	450	190	10	061442	<b>400,00</b>	
1.500	450	190	14	061444	<b>475,00</b>	
2.000	450	190	18	061446	<b>550,00</b>	

**Configure este lavamanos incorporando la grifería que mas se ajuste a sus necesidades.**  
 You can form this washbasin by incorporating the taps that best suit your needs.  
 Vous pouvez former ce lave-mains en intégrant les robinets qui conviennent le mieux à vos besoins.

177



## Calentador de agua instantáneo

Instant water heater  
Chauffe-eau instantané



### Características principales:

Diseñado para proporcionar agua caliente a un solo lavamanos. Calienta el agua mediante su paso por un serpentín eléctrico.

### Main characteristics:

It is designed to provide instantaneous hot water to one hand washbasin, by means of an electric coil.

### Caractéristiques principales:

Il est conçu pour fournir de l'eau chaude instantanée au lave-main, au moyen d'une bobine électrique.



Temperatura de salida del agua de 35° a 50°  
Leaving water temperature 35° - 50°  
Température de sortie d'eau 35° - 50°

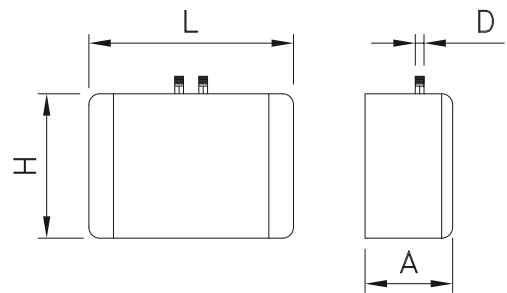

### Dimensiones

L	A	H	D	°C	l/min	Potencia Power Puissance	Tensión Voltage Tension	Frecuencia Frequency Fréquence	Kg	Barcode	€
187	80	132	3/8"	50°C	2,0	3.500 W	230 V	580 Hz.	1,1	461456	248,00

## Conjunto lavamanos y fregadero mural

Double bowl wall-mounted hand wash basin-sink  
Évier lave-mains suspendu à deux bacs

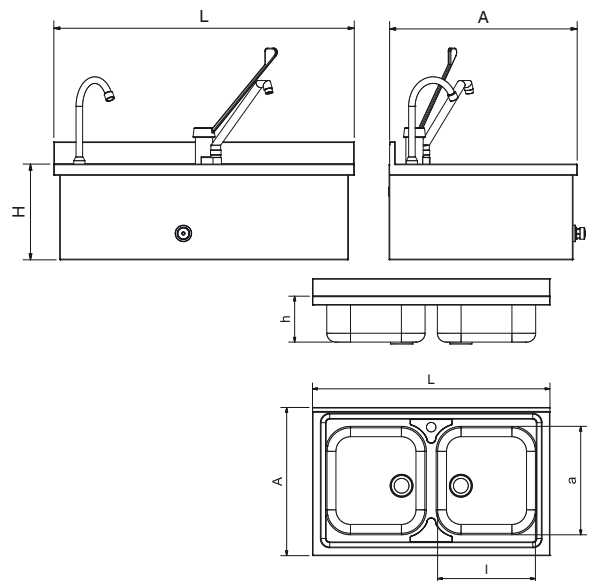

Provistos de mezclador antirretorno  
Supplied with no-return mixing valve  
Munies de valve antiretour mélangeuse

### Dimensiones

### Dimensiones de la cubeta

L	A	H	I	a	h	Kg	Barcode	€
800	500	255	330	360	160	12	054202	720,00



**Pedal de un agua M-M de 1/2"**  
M-M 1/2" single inlet water pedal  
Pédale à une eau M-M d'1/2"



425 460602 **47,00**



**Pedal mezclador de agua fría y caliente M-M-M de 1/2"**  
M-M-M 1/2" hot and cold-water mixer pedal  
Pédale mélangeuse eau froide et eau chaude M-M-M d'1/2"

770 460604 **84,00**



**Pulsador temporizado M-M de 1/2"**  
Push-button M-M 1/2" timer  
Bouton-poussoir temporisé M-M d'1/2"

390 460404 **34,00**



**Kit de juntas para pulsador temporizado**  
Gasket kit for push button timer  
Kit de joints pour bouton-poussoir temporisé

5 460450 **3,20**



**Grifo de palanca un agua M-M de 1/2"**  
Twist waste handle tap M-M 1/2"  
Robinet à levier M-M d'1/2"

1.350 463802 **92,00**



**Pulsador hidráulico con latiguillos 1/2"**  
Hydraulic push button with flexible hoses 1/2"  
Poussoir hydraulique et flexibles 1/2"

900 460408 **126,00**



**Pedal hidráulico de gran caudal**  
Hydraulic pedal high flow  
Pédale hydraulique d'grand débit



1.200 460412 **165,00**



**Latiguillos flexibles en malla de acero inoxidable H-H de 1/2"**  
H-H 1/2" stainless-steel flexible hoses  
Flexibles en maille d'acier inoxydable H-H d'1/2"

400 mm	100	461202	<b>4,00</b>
550 mm	120	461206	<b>5,00</b>
700 mm	140	461208	<b>5,00</b>
800 mm	180	461210	<b>6,00</b>
900 mm	200	461212	<b>7,00</b>
1.200 mm	240	461214	<b>6,50</b>
1.450 mm	345	461216	<b>8,00</b>



**Caños fijo y caño giratorio 1/2"**  
Fixed and rotating spouts 1/2"  
Jets fixe et giratoire 1/2"

**Fijo**  
Fixed  
Fix 420 461002 **34,00**

**Giratorio**  
Rotating  
Giratoire 330 461004 **34,00**



**Caño giratorio XS 1/2"**  
XS rotating spout 1/2"  
Jet giratoire XS 1/2"

**Giratorio**  
Rotating  
Giratoire 315 461008 **30,00**



**Caño giratorio extra bajo 1/2"**  
Extra low rotating spout 1/2"  
Jet giratoire extra bas 1/2"

**Giratorio**  
Rotating  
Giratoire 280 461010 **38,00**







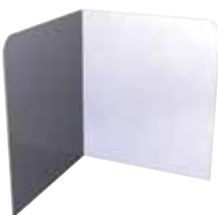



## Repuestos y accesorios para lavamanos

Spare parts for hand wash basins

Pièces de rechange pour lave-mains











Descripción Description Description	Modelo Model Model			
		Gr		€
<b>Peto postizo para acoplar</b> Detachable backsplash to be fitted to hand wash basin Dossieret amovible pour accopler au lave-mains	350x400 mm	1.120	060608	<b>26,00</b>
	450x400 mm	1.450	060602	<b>26,00</b>
<b>Peto lavamanos integral</b> Backsplash for integral hand wash basins Dossieret lavemains intégral	450x400 mm	1.450	060606	<b>28,00</b>
<b>Peto postizo de esquina</b> Corner backsplash Dossieret d'angle	350 + 350x400 mm	2.300	060612	<b>53,00</b>
<b>Papelera modelo Design (lavamanos integral mural)</b> Design model wastepaper bin (wall mounted integral hand wash basins) Corbeille à papier modèle Design (lavemains intégral mural)		2.300	080608	<b>72,00</b>
<b>Papelera-dispensador de papel</b> Paper bags dispenser Distributeur de sacs en papier		2.000	080424	<b>65,00</b>
<b>Válvula con rebosadero para lavamanos de 450x450 mm</b> Drain valve with overflow for 450x450 mm hand wash basins. Valvule de drainage avec déversoir pour lave-mains de 450x450 mm		145	454202	<b>8,00</b>
<b>Válvula de PVC con rebosadero, acabado cromado 1 1/2"</b> Drain valve in PVC with overflow, chrome finished 1 1/2" Valvule de drainage avec déversoir en PVC, finition chromé 1 1/2"		150	454205	<b>23,00</b>
<b>Rebosadero para lavamanos 061402, 061404 y 061448</b> Overflow for 061402, 061404 and 061448 hand wash basins Déversoir pour lave-mains 061402, 061404 et 061448		2	454206	<b>3,50</b>

Descripción Description Description		Gr	Barcode	€
	Tapón inox cubre-agujeros (diámetro 42 mm) Hole-cover plug in stainless steel (diameter 42 mm) Bonde couvre-trou en acier inox (diamètre 42 mm)	16	454602	4,00
	Desagüe flexible para lavamanos autónomo 1 1/2" Flexible drain hose for autonomous wash basin 1 1/2" Tuyau de drainage flexible pour lave main autonome 1 1/2"	125	454260	11,00
	Sifón de desagüe para lavamanos 1 1/2" U-bended drainpipe for hand wash basins 1 1/2" Siphon de drainage pour lave-mains 1 1/2"	169	454402	5,25
	Sifón de PVC acabado cromado 1 1/2" U-bended drainpipe in PVC, chrome finished 1 1/2" Siphon en PVC, finition chromé 1 1/2"	170	454408	13,00
	Sifón de latón cromado 1 1/2" U-bended drainpipe in chrome brass 1 1/2" Siphon en laiton chromé 1 1/2"	1.400	454404	74,00
	Bidón de 11 lts para lavamanos autónomo 11 litres water drum for autonomous wash basin Bidon d'eau de 11 litres pour lave main autonome	360	 461428	15,00
			 461430	11,00
	Pulpo elástico para la sujeción de bolsas de basura en lavamanos Elastic strap for hand wash basins Tendeurs élastiques pour lave-mains	125	464404	6,50
	Rueda de plástico ø50x18 mm. para lavamanos autónomo Plastic wheel ø50x18 mm. for autonomous wash basin Roulette en plastic ø50x18 mm. pour lave main autonome	25	485020	2,30
	Dosificador de jabón encastrable 600 ml. Stainless steel soap dispenser to be embedded 600 ml. Doseur de savon en acier inoxydable pour adosser 600 ml.	580	460218	62,00

## Repuestos y accesorios para lavamanos

Spare parts for hand wash basins

Pièces de rechange pour lave-mains

		Descripción Description Description		
		Gr	Barcode	€
	Hacer agujero en fregadero o lavamanos Drill hole to sink Faire trou à plonge		056802	<b>29,00</b>
	Válvula mezcladora termostática H-H-H de 1/2" H-H-H 1/2" thermostatic mixing valve Valve mélangeuse thermostatique H-H-H d´1/2"	620	461402	<b>85,00</b>
	Mezclador antiretorno M-H-M 1/2" M-F-M 1/2" no-return mixing valve Valve antiretour mélangeuse M-H-M d´1/2"	150	461604	<b>22,00</b>
	Válvula de esfera H-H de 1/2" F-F 1/2" valve Valve H-H d´1/2"	140	461404	<b>5,00</b>
	Válvula antiretorno H-H de 1/2" F-F 1/2" non-return valve Valve antiretour H-H d´1/2"	140	462202	<b>6,50</b>
	"T" mezcladora M-H-M de 1/2" M-F-M 1/2" "T" mixer "T" mélangeur M-H-M d´1/2"	80	461602	<b>4,50</b>
	Codo a 90° M-H de 1/2" M-F 1/2" 90° angle Coude à 90° M-F d´1/2"	80	461802	<b>2,20</b>
	Unión M-M de 1/2" M-M 1/2" union Jonction M-M d´1/2"	20	462002	<b>1,40</b>





## Fuentes de agua sin refrigeración

La combinación de un cuidado diseño y una gran calidad en los materiales empleados, dan como resultado una gama de fuentes que se adaptan a las exigencias actuales cumpliendo con todas las normativas vigentes.

Su construcción en acero inoxidable permite su utilización en interiores o exteriores.

Los modelos murales se pueden instalar a una altura más baja, para niños o personas discapacitadas.

Ideal en oficinas, vestuarios, instalaciones deportivas, colegios, centros comerciales, etc.

## Drinking fountains without refrigeration unit

The combination of careful design and high quality materials used, resulting in a range of sources to suit the current requirements in compliance with all regulations.

Made in stainless steel. They can be placed indoors or outdoors.

The wall models can be installed at a lower height for children or people who need it.

Recommended for offices, locker rooms, sports facilities, schools, shopping centers, etc.

## Les sources d'eau sans réfrigération

La combinaison d'une conception attentive et matériaux de haute qualité utilisés, résultant dans une variété de sources pour répondre aux exigences actuelles de conformité avec tous les règlements.

Sa construction en acier inoxydable permet une utilisation à l'intérieur ou à l'extérieur.

Les modèles muraux peuvent être installés à une hauteur inférieure pour les enfants ou les personnes qui en ont besoin.

Idéal pour les bureaux, les vestiaires, des installations sportives, écoles, centres commerciaux, etc.

## Fuente de columna

Column fountain  
Fontaine colonne



### Características principales:

Su construcción en acero inoxidable permite su utilización en interiores o exteriores. Ideal en oficinas, vestuarios, instalaciones deportivas, colegios, centros comerciales, etc.

### Main characteristics:

Made in stainless steel. They can be placed indoors or outdoors. Recommended for offices, locker rooms, sports facilities, schools, shopping centers, etc.

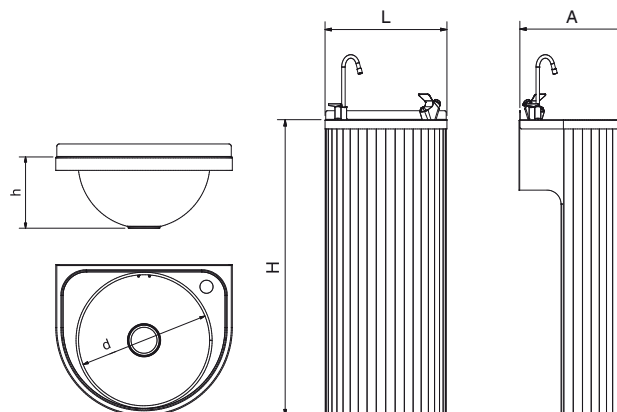

### Caractéristiques principales:

Sa construction en acier inoxydable permet une utilisation à l'intérieur ou à l'extérieur. Idéal pour les bureaux, les vestiaires, des installations sportives, écoles, centres commerciaux, etc.

Dimensiones Dimensions Dimensions			Dimensiones de la cubeta Tank dimensions Dimensiones du bac				
L	A	H	d	h	Kg	Barcode	€
350	300	850	260	115	7	064206	295,00

## Fuente de columna de pedal

Pedal-operated column fountain  
Fontaine colonne avec pédale



### Características principales:

Su construcción en acero inoxidable permite su utilización en interiores o exteriores. Ideal en oficinas, vestuarios, instalaciones deportivas, colegios, centros comerciales, etc.

### Main characteristics:

Made in stainless steel. They can be placed indoors or outdoors. Recommended for offices, locker rooms, sports facilities, schools, shopping centers, etc.

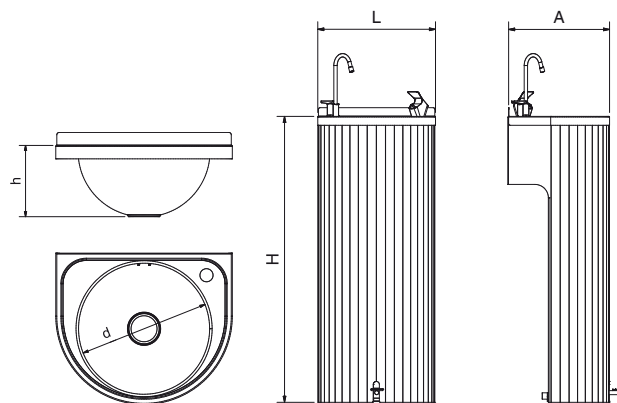

### Caractéristiques principales:

Sa construction en acier inoxydable permet une utilisation à l'intérieur ou à l'extérieur. Idéal pour les bureaux, les vestiaires, des installations sportives, écoles, centres commerciaux, etc.

Dimensiones Dimensions Dimensions			Dimensiones de la cubeta Tank dimensions Dimensiones du bac				
L	A	H	d	h	Kg	Barcode	€
350	300	850	260	115	7	064212	330,00

**Fuente mural redonda**  
Wall-mounted round fountain  
Fontaine mural ronde

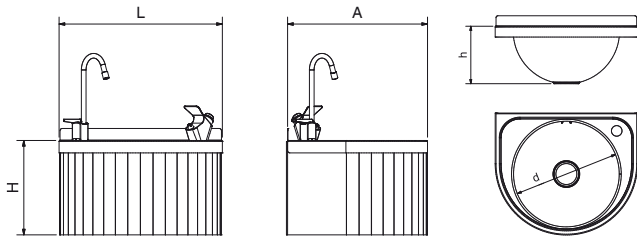

Dimensiones Dimensions Dimensions			Dimensiones de la cubeta Tank dimensions Dimensiones du bac			Kg	Barcode	€
L	A	H	d	h				
350	300	200	260	115	6	064208	270,00	



**Fuente mural de esquina**  
Wall-mounted corner fountain  
Fontaine mural d'angle

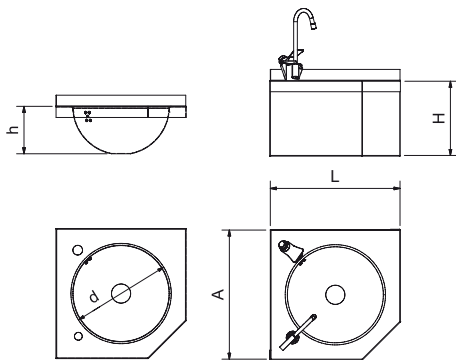

Dimensiones Dimensions Dimensions			Dimensiones de la cubeta Tank dimensions Dimensiones du bac			Kg	Barcode	€
L	A	H	d	h				
350	350	205	260	115	3	064210	350,00	



**Fuente de fijación mural**  
Wall-mounted fountain  
Fontaine fixation murale

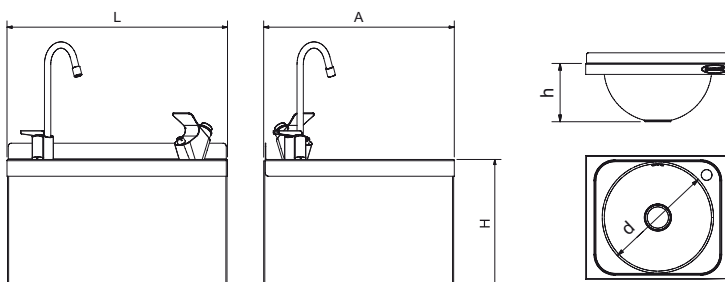



Dimensiones Dimensions Dimensions			d	h	Kg	Barcode	€
L	A	H					
350	300	200	260	115	2,08	064204	250,00

## Accesorios para fuentes M 3/8"

Spare parts for water fountains M 3/8"

Pièces de rechange pour fontaines d'eau M 3/8"

Descripción Description Description			
	Gr	Barcode	€
	Grifo para fuente de agua sin pulsador Tap for drinking fountain without push-button Robinet pour fontaine sans bouton-poussoir	115 464248	32,00
	Grifo pulsador para fuente Push-button tap for fountain Robinet poussoir pour fontaine	125 464250	35,00
	Grifo llena-jarras Tap to fill up jars Robinet pour remplir pots	130 464252	29,00